



MIO 23

User manual



Scandomestic A/S · Thrigesvej 2 · DK-8600 Silkeborg
T + 45 7242 5571 · F + 45 8622 5571 · scandomestic.dk

INSTRUCTION MANUAL

HOUSEHOLD USE ONLY - IMPORTANT SAFETY INSTRUCTIONS

When using your Electric Oven /convection, basic safety precautions should always be observed, including the following:

- 1 Read all instructions.
- 2 Do not touch hot surfaces. Always use handles or knobs.
- 3 Close supervision is necessary when any appliance is used by or near children.
- 4 To protect against electric shock, do not immerse cord, plug or any parts of the oven in water or any other liquids.
- 5 Do not let cord hang over edge of table or counter, or touch hot surfaces.
- 6 Do not operate appliance with damaged cord or plug or after the appliance malfunctions or has been damage in any manner. Return appliance to the nearest authorized service facility for examination, repair or adjustment.
- 7 The use of accessory attachments not recommended by the appliance manufacturer may cause hazard or injury.
- 8 Do not place on or near a hot gas or electric burner.
- 9 When operating the oven, keep at least four inches of free space on all sides of the oven to allow for adequate air circulation.
10. Unplug from outlet when not in use and before cleaning. Allow to cool before putting on or taking off parts, and before cleaning.
- 11 To disconnect, turn the time control to OFF, then remove the plug. Always hold the plug, and never pull the cord.
- 12 Extreme caution must be used when moving a drip pan containing hot oil or other hot liquids.
- 13 Do not cover any part of the oven with metal foil. This may cause the oven to overheat.
- 14 Use extreme caution when removing the tray, racks or disposing of hot grease or other hot liquids.
- 15 Do not clean the inside of the oven with metal scouring pads, pieces can break off the pad and touch electrical parts, creating a risk of electric shock.
- 16 Oversized foods or metal utensils must not be inserted in a electric oven as they may create a fire or risk of electric risk.
- 17 A fire may occur if the oven is covered or touching flammable material, including the curtains, draperies, walls, and the like, when in operation. Do not store any item on top of the appliance when in operation.
- 18 Extreme cautions should be exercised when using cooking or baking containers constructed of anything other than metal or ovenproof glass.
- 19 Be sure that nothing touches the top or bottom elements of the oven.
- 20 Do not place any of the following materials in the oven: cardboard, plastic, paper , or anything similar.
- 21 Do not store any materials other than manufacturer's recommended accessories in this oven when not in use.
- 22 Always wear protective, insulated oven gloves when inserting or removing items from the hot oven.
- 23 This appliance has a tempered, safety glass door. The glass is stronger than ordinary glass and more resistant to breakage. Tempered glass can still break around edges. Avoid scratching door surface or nicking edges.
- 24 This appliance is OFF when the Timer Control button is in the "OFF" position.
- 25 Do not use outdoors.
- 26 Do not use appliance for other than intended use.
- 27 Surfaces are liable to get hot during use
- 28 The door or the outer surface may get hot when the appliance is operating.
- 29 Appliances are not intended to be operated by means of an external timer or separate remote-control system.
- 30 This appliance can be used by children aged from 8 years and above and persons with reduced physical, sensory or mental capabilities or lack of experience and knowledge if they have been given supervision or instruction concerning use of the appliance in a safe way and understand the hazards involved. Children shall not play with the appliance. Cleaning and user maintenance shall not be made by children unless they are older than 8 and supervised.
- 31 Keep the appliance and its cord out of reach of children less than 8 years.
- 32 If the supply cord is damaged, it must be replaced by the manufacturer or its service agent or a similarly qualified person in order to avoid a hazard.
- 33 this appliance must not be supplied through an external switching device, such as a timer

Correct Disposal of this product

This marking indicates that this product should not be disposed with other household wastes throughout the EU. To prevent possible harm to the environment or human health from uncontrolled waste disposal, recycle it responsibly to promote the sustainable reuse of material resources. To return your used device, please use the return and collection systems or contact the retailer where the product was purchased. They can take this product for environmental safe recycling.



Getting To Know Your Convection Oven

MAIN COMPONENT

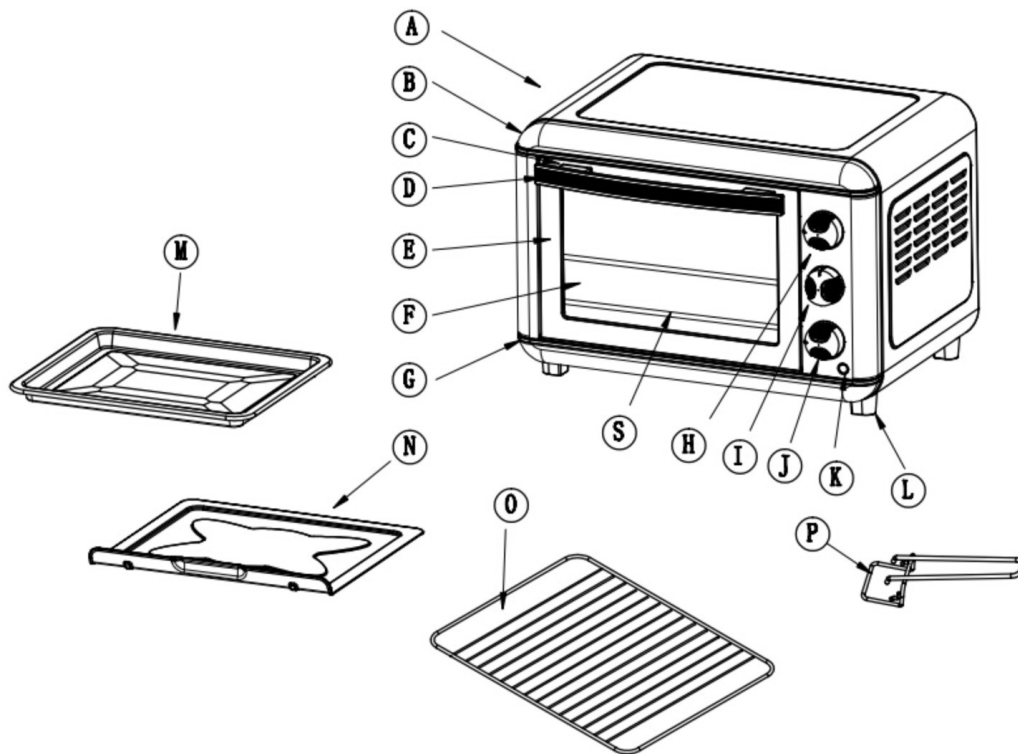

- A: Housing
- B: Front Plate
- C: Upper Decoration strip
- D: Door Handle
- E: Door Frame
- F: Glass Door
- G: Lower Decoration strip
- H: Temperature Control Knob
- I: Function Control Knob
- J: Timer Control Knob
- K: Indicator Cover
- L: Foot
- M: Bake Tray
- N: Crumb Tray
- O: Wire Rack
- P: Tray Handle
- S: Heating element

Read all the sections of this booklet and follow all the instructions carefully.

Before using your convection oven

Before using your electric oven with convection for the first time, be sure to:

- 1 Read all of the instruction included in this manual.
- 2 Make sure that the oven is unplugged and the Time control is in the "OFF" position.
- 3 Wash all the accessories in hot, soapy water or in the dishwasher.
- 4 Thoroughly dry all accessories and re-assemble in oven, plug oven into outlet and you are ready to use your new electric oven.
- 5 After re-assembling your oven, we recommend that you run it at the highest temperature (230°C) on the toast function for approximately 15 minutes to eliminate any packing residue that may remain after shipping. This will also remove all traces of odor initially present.

Please Note: Initial start-up operation may result in minimal smell and smoke (about 15 minutes). This is normal and harmless. It is due to burning of the protective substance applied to the heating elements in the factory.

Using your convection oven

About Convection Cooking

Convection cooking combines hot air movement by means of a fan with the regular features (broil, bake and toast). Convection cooking provides faster cooking in many cases than regular radiant types electric oven. The fan gently sends air to every area of the food, quickly browning, crisping and sealing in moisture and flavor. It produces more even temperature all around the food by air movement, so that food cooks/bakes/broils evenly versus the normal ovens hot and cold spots. The convection feature allows cooking/baking at lower temperatures, which saves energy and helps keep the kitchen cooler. Convection air is superheated and it circulates around the food so it cooks food significantly faster than conventional ovens.

Using your convection oven

Please familiarize yourself with the following oven functions and accessories prior to first use:

- Temperature Control(H): choose the desired temperature from 100°C to 230°C for baking broiling or toasting.
- Function Control(I): this oven (CS2801C) is equipped with four positions for a variety of cooking needs
- Four stages switch heating selector: Off/Broil/Bake/Toast/Off.

Broil: For broiling fish, steak, poultry, pork chops, etc. (upper heating)

Bake: For cakes, pies, cookies, poultry, beef, pork, etc. (lower heating)

Toast: For bread, muffins, frozen waffles, pizza ,etc. (upper & lower heating)

- Time Control(J): when you turn activate the timer segment of the control, turn to the right (clockwise) to toast or use as a timer. This function also has a bell rings at the end of the programmed time.
- Convection fan: The convection fan works automatically on every setting. When the desired temperature and Function is chosen, set the timer at the desired position. The convection fan will start operating.
- Power **"ON"** neon light: It's illuminated whenever the oven is turned on.
- Bake Tray(M): For use in broiling and roasting meat, poultry, fish and various other foods. Also to be used when using the rotisserie handle to catch the drippings.
- Wire Rack(O): For toasting, baking, and general cooking in casserole dishes and standard pans.

WARNING: TO AVOID RISK OF INJURY OR BURNS, DO NOT TOUCH HOT SURFACES WHEN OVEN IS IN USE. ALWAYS USE OVEN MITTS.

CAUTION: Always use extreme care when removing bake tray, wire rack or a any hot container from a hot oven. Always use the rack handle, or an oven mitt when removing hot items from the oven.

Roasting In Your Oven

Roast your favorite cut of meat to perfection. The oven can cook up to an 8-lb. chicken or turkey and up to a 6-lb. roast. A guide has been provided to assist you with roasting times. However,

we suggest that you periodically check the cooking progress with a meat thermometer. For best results we recommend that you preheat the oven for 15 minutes on 230°C. We do not recommend the use of oven roasting bags or glass containers in the oven. Never use plastic cardboard, paper or anything similar in the oven.

Operation

- Place the wire rack in the oven at the lowest position.
- Place food to be cooked in any roasting pan. If you wish to use the bake tray (broil/drip pan), then you do not need to insert the wire rack because the bake tray supports itself on the oven support guides.
- Set the temperature control knob to the desired temperature.
- Turn the time control to the **"ON"** position.
- To check or remove roast, use the tray handle provided to help you slide the roast in and out.
- When cooking is complete, turn the time control knob to the **"OFF"** position.

Roasting Guide

Cooking results may vary . Adjust these times to your individual requirements

MEAT	OVEN TEMP	TIME PER LB.
BEEF ROAST	230°C	30-35min
PORK ROAST	230°C	40-45min
HAM	230°C	35-40min
CHICKEN	230°C	25-35min
TURKEY	230°C	25-30min

Note: All roasting times are based on meats at refrigerator temperature . Frozen meats may take considerably longer. Therefore, use of a meat thermometer is highly recommended.

BROIL

For best results, it is recommended that your preheat the oven for 15 minutes on 230°C.

Operation

- Set the temperature Control Knob to 230°C.
- Turn function control to BROIL. and Preheat the oven.
- Place the wire rack on the bake tray.
- Place food on the wire rack and slide into the top rack.
- Food should be placed as close as possible to the top heating element without touching it.
- Set temperature control to appropriate temperature.
- Brush food with sauces or oil, as desired.
- Turn time control to **"ON"**.
- It is advisable to leave the door slightly ajar
- Turn food over midway through the prescribed cooking time.
- When broiling is complete, turn the time control to **"OFF"**.

Broiling Guide

Cooking results may vary. Adjust these times to your individual requirements. Also, check often during broiling to avoid over-cooking.

MEAT	OVEN TEMP	COOKING TIME
RIB STEAK	230°C	25-30 min
T-BONE STEAK	230°C	25-30 min
HAMBURGER	230°C	25-28 min
PORK CHOPS	230°C	40-45 min
LAMB CHOPS	230°C	30-40 min
CHICKEN LEGS	230°C	30-35 min
FISH FILETS	230°C	20-25 min
SALMON STEAKS	230°C	20-25 min

Note: All broiling times are based on meats at refrigerator temperature. Frozen meats may take considerably longer. Therefore, use of a meat thermometer is highly recommended.

Toasting

Please note that the TOAST function uses all the heating elements. Large capacity oven allows for toasting 4 to 6 slices of bread, 6 muffins, frozen waffles or frozen pancakes. When toasting only 1 or 2 items, place food on the bake rack in the center of the oven.

Operation

- Set the Temperature Control Knob to 230°C.
- Turn the function control knob to TOAST.
- Place food to be toasted on the wire rack.
- Turn the time control knob to **"ON"**.
- Bell will ring to signal the end of the toast cycle.

Note: Wire Rack should be positioned in the middle of the oven with the indentations pointing down.

Baking

Please note that the BAKE function uses only the bottom heating elements. For best results, it is recommended that you preheat the oven for 15 minutes on 230°C.

Operation

- Set the temperature Control Knob to 230°C.
- Turn function control to BAKE. Then Preheat the oven.
- Place the wire rack on the lowest or middle rack support guide.
- Place food on the wire rack and slide into the rack.
- Food should be placed as close as possible to the lower heating element without touching it.
- Set temperature control to appropriate temperature.
- Brush food with sauces or oil, as desired.
- Turn time control to **"ON"**.

- It is advisable to leave the door slightly ajar
- Turn food over midway through the prescribed cooking time.
- When BAKE is complete, turn the time control to **"OFF"**.

Positioning of the Wire Racks

Cookies – Use bottom and middle Support Guides.

Layer Cakes – Use bottom Support Guide only (bake one at a time).

Pies – Use bottom and middle Support Guides.

CAUTION: Always use extreme care when removing bake tray, wire rack or a any hot container from a hot oven. Always use the rack handle, or an oven mitt when removing hot items from the oven.

Care & Cleaning

Warning: Be sure to unplug the oven and allow it to cool before cleaning.

Your oven features a continuous clean coating that automatically cleans itself during normal operation. Any spattering that occurs while cooking and comes into contact with the continuous coating is oxidized while the oven is in operation. If desired, wipe the walls with a damp sponge, cloth or nylon scouring pad and mild detergent. **DO NOT USE STEEL WOOL SCOURING PADS, ABRASIVE CLEANERS OR SCRAPE THE WALLS WITH A METAL UTENSIL, AS ALL OF THESE METHODS MAY DAMAGE THE CONTINUOUS CLEAN COATING.**

All accessories should be washed in hot soapy water or can be cleaned in a dishwasher. The door can be wiped with a damp sponge and wiped dry with a paper or cloth towel. Clean the outside with a damp sponge. **DO NOT USE AN ABRASIVE CLEANER AS IT MAY DAMAGE THE EXTERIOR FINISH.**

DO NOT USE AN ABRASIVE CLEANER OR STEEL WOOL SCOURING PAD ON THE DRIP PAN AS IT MAY DAMAGE THE PORCELAIN ENAMEL FINISH.

LET ALL PARTS AND SURFACES DRY THOROUGHLY PRIOR TO PLUGGING OVEN IN AND USING.